



ICP®-Powered MEMS Shock Accelerometer with DC Response

Introducing PCB®'s Patent Pending ICPR™ Technology

Highlights

- State-of-the-art MEMS sensing element
- Uses std 2-20mA ICP® signal conditioning
- Patent pending technology
- DC response provides undistorted signals
- No zero-shift provides accurate integration to velocity and displacement
- Mechanical stops improve survivability
- Slight damping for reduced resonance amplification
- Low transverse sensitivity
- Excellent amplitude linearity
- Drop-in replacement for PE sensors

Commercial Applications

- Consumer electronics testing
- Pile driving
- Down-hole oil exploration
- Shot counting
- Jack hammer testing
- Golf club impact testing

Military & Defense Applications

- Smart fuzes
- Weapons data recorders
- Explosive environments (pyroshock)
- Safe and arm
- Penetrator tests
- Metal-to-metal impact / Armor piercing
- Blast loading of structures



A full-bridge MEMS sensing element powered with an ICP® signal conditioner? Turning a 4-wire device into a 2-wire sensor? Yes! With PCB®'s new patent pending ICPR™ technology, we have combined the benefits of MEMS sensing elements, for high-amplitude shock applications, with that of two-wire, low impedance, ICP® signal conditioning.

By integrating circuitry into the sensor, the current supply from any ICP®-style conditioner is transformed to excite the Wheatstone bridge MEMS sensing element. The circuitry then amplifies the differential voltage output and adds it to the ICP® bias voltage, so it "looks" like a typical ICP® sensor to your signal conditioner (See "What is ICPR™?" for further technical details).

MEMS-based shock sensors have lower transverse sensitivity, improved amplitude linearity, and minimal zero-shift compared to traditional piezoelectric (PE) shock sensors. Minimizing zero-shift by itself, is critical to reduce the error made when integrating to velocity or displacement. PCB®'s proven air-damped, high-amplitude MEMS sensing element is manufactured with the latest advances in silicon etching techniques and equipment, to achieve performance levels that previously have not been attainable.

With ICPR™, the ability to drive these high-amplitude MEMS sensing elements with ICP® signal conditioners, not only makes life simpler for users who'd like to upgrade their ICP® PE sensors to piezoresistive (PR) MEMS sensors, but also enables DC response! With a DC-coupled, ICP® signal conditioner, like PCB®'s new Model 482C27 (see back page), the Series 3531 frequency response starts at 0Hz. This means no signal distortion, especially for longer duration events.

With the best of both worlds, the Series 3531 are intended to fulfill the most demanding aerospace, commercial, military, and industrial application requirements. They are capable of measuring long duration, transient motion, as well as responding to and surviving extremely fast rise times, typical of high-G shock events. With its 1/4 - 28 mounting stud, it is a drop in replacement for most PE shock sensors.

As with all PCB® instrumentation, these sensors are complemented with toll-free applications assistance, 24-hour customer service, and are backed by our "Lifetime Warranty Plus" – A Total Customer Satisfaction no risk policy. Should this sensor ever fail, PCB® will: Replace it or repair it for life, *plus* offer a full refund for the first year.

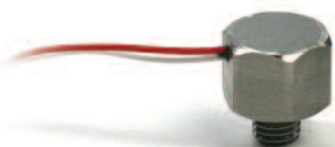

Series 3531
ICPR™ MEMS Shock Accelerometers



The best of both worlds...

What is ICPR™?

A description of the patent-pending ICPR™ circuit must include overviews of the ICP® system, as well as bridge conditioning, since it combines elements of both.

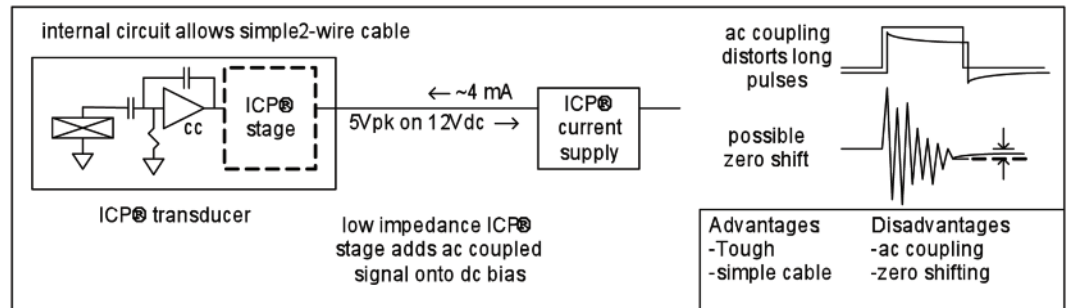

Prior to the use of ICP®, (the original Internal Electronic PiezoElectric scheme, commonly known as IEPE), users of Piezoelectric (PE) transducers had to painstakingly maintain extremely high impedance of circuitry, insulation, and cables, in order to maintain reasonable bandwidth and signal-to-noise levels. These requirements were greatly relaxed by placing miniature electronics within the transducer, as shown above. The electronics were powered by a DC current, provided by the supply at the other end of the two-wire cable. The circuit converted signals to low impedance analog voltage riding on a DC bias level, such that supply and signal were carried on the same wire. System and cabling costs were greatly reduced, as was susceptibility to noise. The convenience and cost-effectiveness of the ICP® scheme triggered the overwhelming predominance of the ICP® interface over charge mode PE transducers.

PE transducers are as a class, extremely rugged, and would otherwise be an excellent choice for shock measurement, except for the fact that they are inherently AC-coupled. As shown in figure, AC-coupled signals cannot maintain a static signal, instead the response to a square wave decays away and distorts the pulse shape. Worse, they exhibit a tendency to take on a zero-shift under certain shock conditions. Shifted output cannot be accurately integrated to get velocity and displacement, which are parameters frequently needed by users of accelerometers. Researchers found that piezoresistive (PR) sensors were less prone to zero-shift and were DC-coupled, solving both the above problems. PR sensors have therefore become the preferred sensor to use for shock measurements during long duration events, and particularly when integration was required.

But PR sensors have their own demands in conditioning and cabling, as described in the figure below. And they have their own weaknesses: particularly MicroElectroMechanical Systems (MEMS) sensors, being made of single crystal silicon, can be brittle and prone to failure by resonant amplification.

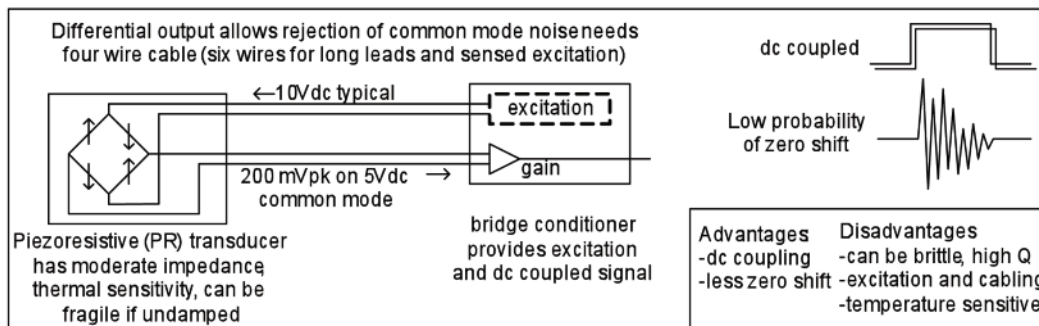

With improvements, such as the low damping and stops incorporated in PCB's Series 3501 and Series 3991 family of MEMS sensors, the weaknesses have been largely overcome. Combining the MEMS sensor with the patent pending ICPR™ circuitry depicted in the figure below, the evolution of shock sensors ascends to its peak. The internal circuitry starts with the familiar two-wire current-driven source, then adds an excitation circuitry which compensates for the thermal sensitivity slope of PR, adds gain in an instrumentation amplifier, and translates its DC-coupled output to the ICP® bias, giving you a shock accelerometer with the best of both worlds!

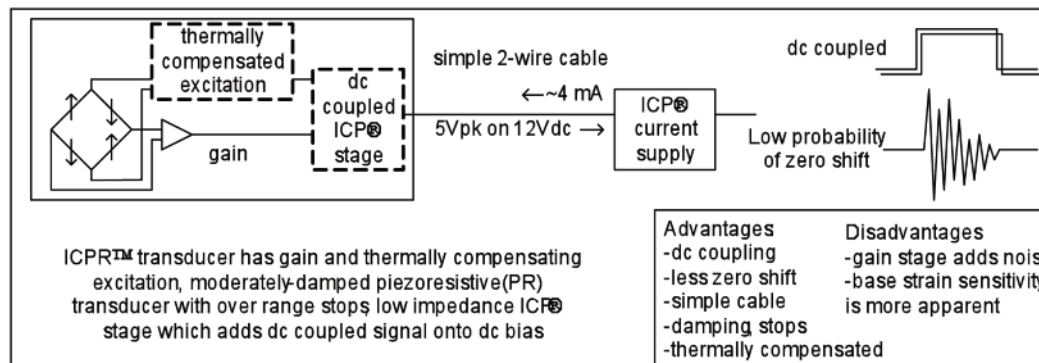



ICPR™ MEMS Shock Accelerometers

Model Number	3531A121KG*	3531A125KG	3531A1210KG	3531A1250KG	3531A12100KG
Sensitivity (± 25%)	5 mV/G	1 mV/G	0.5 mV/G	0.1 mV/G	0.05 mV/G
Measurement Range	1000 G	5000 G	10000 G	50000 G	100000 G
Frequency Range (± 1dB)	5000 Hz	10000 Hz	10000 Hz	20000 Hz	20000 Hz
Resonant Frequency	> 20000 Hz	> 60000 Hz	> 60000 Hz	> 100000 Hz	> 100000 Hz
Non-Linearity	2 % FS				
Transverse Sensitivity (Maximum)	3 %				
Environmental					
Overload Limit (Shock)	± 10000 G	± 60000 G	± 60000 G	± 100000 G	± 100000 G
Temperature Range (Operating)	-65 to +250 °F -54 to +121 °C	-65 to +250 °F -54 to +121 °C	-65 to +250 °F -54 to +121 °C	-65 to +250 °F -54 to +121 °C	-65 to +250 °F -54 to +121 °C
Sensitivity Shift Due to Temperature	± 5 %				
Zero-Shift Due to Temperature	3 % FS				
Electrical					
Constant Current Excitation	4 to 20mA	2 to 20mA	2 to 20mA	2 to 20mA	2 to 20mA
Broadband Resolution (1 to 10000 Hz)	0.05 Grms	0.5 Grms	0.5 Grms	2 Grms	2 Grms
Excitation Voltage	18 to 28V dc				
Output Voltage (at specified range)	± 5				
Output Impedance	< 100 Ohms				
Output Bias Voltage	12 to 14 V				
Electrical Isolation (Case)	>10 ⁹ Ohms				

Physical	
Sensor	Piezoresistive MEMS
Housing Material	Titanium
Sealing	Epoxy
Size (Hex x Length)	0.5 x 0.7 in (12.7 x 17.8 mm)
Weight (without Cable)	0.2 oz (6 gm)
Electrical Connector	Integral Cable
Cable Type	031 Twisted Pair
Cable Termination	10-32 Coaxial Plug
Cable Length	10 ft (3 m)
Mounting	1/4-28UNF Male
Mounting Torque	24 lbf-in

Supplied Accessories	
ACS-62 Shock Calibration	
ACS-22 NIST Traceable Frequency Response (100 Hz to ±1 dB point)	
Optional Versions	
Metric Mounting Thread	M6 x 0.75 Male

Notes	
All specifications are at room temperature and 4mA excitation unless otherwise specified.	

*Will only be available in March 2010.

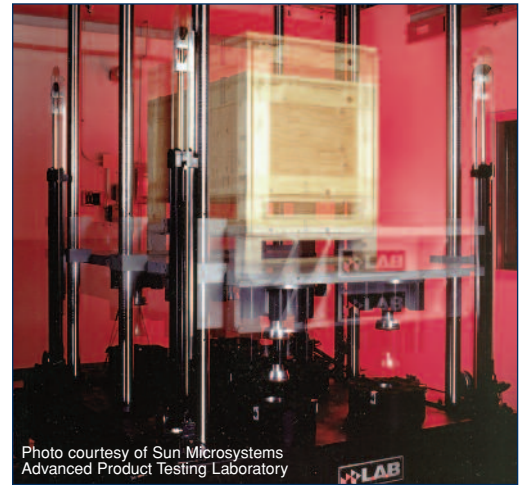
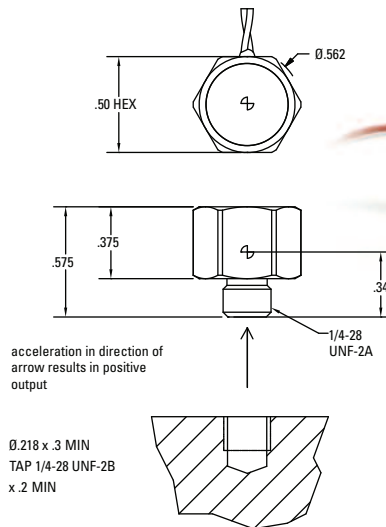

Model Numbering System for Series 3531 ICPR™ MEMS Shock Accelerometers

1.) 3531A Single axis, ICPR™ MEMS Shock Accelerometer					
2.) Configuration					
12	Titanium housing, mounted with integral 1/4-28" thread stud, side cable exit				
3.) Measurement Range					
100KG	± 100,000 G				
50KG	± 50,000 G				
10KG	± 10,000 G				
5KG	± 5,000 G				
1KG	± 1,000 G				
4.) Integral Cable Length (add only if other than standard 10 ft length)					
/ XXX	Specify XXX, as desired in feet				
5.) Cable Termination (add only if selecting other than standard 10-32 coaxial plug connector)					
AC	BNC plug				
AB	BNC jack				
Example					
3531A	12	50KG	/020	AC	Single axis, titanium housing, mounted with integral 1/4-28" thread stud, side cable exit, 50,000 G range, 20 ft cable terminating in a BNC plug



MEMS Sensor Signal Conditioner

Model Number	482C27
Channels	4
Sensor Input Types	Differential/Single-ended MEMS/Bridge, ICP®/Voltage
Compatible Sensor Series	350X, 360X, 371X, 374X, 3991, load cells
Gain	x0.1 to x2000; x0.1 to x200 [1]
Gain Increment	0.1
Output Range	±10 V
Frequency Response	DC to 100k Hz (-3dB)
Temperature Range (Operating)	+32 to +122 °F 0 to +50 °C
Excitation Voltage	0 to 12 VDC unipolar or bipolar [2]
Computer Controller	Ethernet/RS-232
Power Required	9 to 18 VDC [3]
Input Connectors	(4) 8-socket mini DIN, (4) BNC Jacks
Output Connectors	BNC Jacks
Size (Height x Width x Depth)	3.2 in x 8.0 in x 5.9 in 8.1 cm x 20 cm x 15 cm
Weight	2.25 lb 1.021 kg
Supplied Accessories	
(1) 017AXX Power Cord; (1) 488A14 Universal Power Adaptor; (1) MCSC Control Software	
Additional Accessories	
Auto Lighter Adaptor	488A13
Input Mating Connector(s)	8-pin mini DIN, AC
Additional Versions	
8-channel 19" rack mount version, computer control only	483C28
Notes	
[1] Maximum gain for bridge/MEMS input is x2000 and for ICP®/voltage input is x200.	
[2] In bipolar mode, +Vexc and -Vexc track each other. They are equal and opposite.	
[3] Supplied with 85 to 264 VAC, 47 to 400 Hz Universal Power Adaptor.	



Typical Rear Panel

The Model 482C27 four-channel, benchtop signal conditioner is full-featured and cost effective. It offers low noise operation and simplicity of use. Each channel is selectable between two input types: Bridge/MEMS or ICP®/Voltage.

For the bridge inputs, this model offers 0 to 12 VDC unipolar or bipolar excitation voltage for use with single-ended or differential MEMS and bridge sensors, like load cells and reaction torque sensors. This model features incremental gain of x0.1 to x2000, auto zero, auto balance, AC/DC coupling, normalization, and shunt calibration. The bridge inputs are compatible with full bridge sensors as well as ½ and ¼ bridge sensors, with internal switchable bridge completion resistors.

For the ICP® inputs, the model offers 0 to 20 mA of constant current excitation, to power ICP® sensors or in-line ICP® charge converters. This model features incremental gain of x.1 to x200, normalization, and AC/DC coupling.

The base unit of this model is powered from 9 to 18 VDC, however, it is supplied with a universal voltage, AC power adaptor. Optional auto lighter adaptor, Model 488A13, is also available.

As with all PCB® instrumentation, this model is complemented with toll-free application assistance, 24-hour customer service, and is backed by a no-risk policy that guarantees satisfaction or your money refunded.



483C28
8-channel version, computer control only



3425 Walden Avenue, Depew, NY 14043-2495 USA

Toll-Free in USA 800-828-8840

24-hour SensorLineSM 716-684-0001

Fax 716-684-0987 E-mail info@pcb.com

www.pcb.com

AS9100 CERTIFIED ■ ISO 9001 CERTIFIED ■ A2LA ACCREDITED to ISO 17025

© 2009 PCB Group, Inc. In the interest of constant product improvement, specifications are subject to change without notice. PCB, ICP, Modally Tuned, Spindler, Swiveler and TORQDISC are registered trademarks of PCB Group. SoundTrack LXT, Spark and Blaze are registered trademarks of PCB Piezotronics. SensorLine is a service mark of PCB Group. All other trademarks are properties of their respective owners.

AD-ICPR-3531-1209

Printed in U.S.A.

PCB Piezotronics, Inc. manufactures accelerometers, force sensors, load cells, microphones, pressure transducers and transmitters, strain sensors, torque sensors, vibration sensors, signal conditioners, sound level meters, noise dosimeters, cables, and accessories. This instrumentation is used for test, measurement, monitoring, and feedback control requirements in automotive, aerospace, industrial, R&D, military, educational, commercial, industrial hygiene, environmental noise monitoring and OEM applications. PCB Piezotronics offers exceptional customer service, 24-hour technical assistance, and a **Total Customer Satisfaction** guarantee.

Visit www.pcb.com to locate your nearest sales office